

- IP67/66 & Type 4/4X/13
- -40°C to +66°C (-40°F to +151°F)
- DC: 2.5Kg (5.5lb); AC: 3.0Kg (6.5lb)
- CE, UKCA, EAC & Russian Maritime Register approved

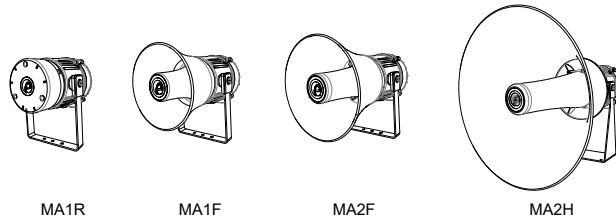

Unit Type Code	Nominal Voltage	Voltage Range	Nominal Current P1 (mA)	Nominal Current P2 (mA)	Nominal Current P3 (mA)	Sound Pressure Level P1, dB(A)			Sound Pressure Level P2, dB(A)			Sound Pressure Level P3, dB(A)				
						Max*	Nom ¹	\bar{x} ²	Max*	Nom ¹	\bar{x} ²	Max*	Nom ¹	\bar{x} ²		
MA1RDC024	12 Vdc / 24 Vdc / 48Vdc	10-60Vdc	280/			113.8	110.7	109.7								
MA1FDC024			224/122			116.8	113.7	112.7								
MA2FDC024	12 Vdc / 24 Vdc / 48Vdc	10-60Vdc		376/391/223 ³	440/888/453				120.0	118.6	114.7	123.4	120.1	118.0		
MA2HDC024				378/391/223	440/888/453 ³				125.3	122.5	120.1	128.6	125.9	123.1		
MA1RAC230	115 Vac / 240Vac	100 - 230 Vac 50/60Hz	100/64			113.8	110.7	109.7								
MA1FAC230							116.8	113.7	112.7							
MA2FAC230	115 Vac / 240Vac	100 - 230 Vac 50/60Hz	100/64						120.0	118.6	114.7	123.4	120.1	118.0		
MA2HAC230							125.3	122.5	120.1	128.6	125.9	123.1				

*Max = Tone 4 / ¹Nom. = Tone 44 / ² \bar{x} = Average over 64 tones / ³ Denotes factory P2/P3 setting

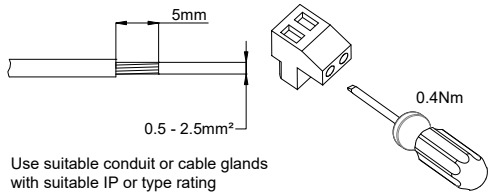

Attention: Installation must be carried out by an electrician in compliance with the latest codes and regulations.
 Attention: L'installation doit être effectuée par un électricien conformément aux derniers codes et réglementations.
 Achtung: Die Installation muss von einem Elektriker gemäß den neuesten Vorschriften und Bestimmungen durchgeführt werden.
 Attenzione: L'installazione deve essere eseguita da un elettricista in conformità con i codici e le normative più recenti.
 Atención: La instalación debe ser realizada por un electricista de acuerdo con los últimos códigos y regulaciones.
 Atencão: A instalação deve ser realizada por um electricista de acordo com os códigos e regulamentos mais recentes.
 ВНИМАНИЕ: установка должна выполняться электриком в соответствии с последними нормами и правилами.
 Attention: Disconnect from power source before installation or service to prevent electric shock
 Attention: Débranchez-le de la source d'alimentation avant l'installation ou l'entretien pour éviter tout choc électrique.
 Achtung: Vor Installation oder Wartung von der Stromquelle trennen, um einen Stromschlag zu vermeiden.
 Attenzione: scollegare dall'alimentazione prima dell'installazione o dell'assistenza per evitare scosse elettriche.
 Atención: desconéctelo de la fuente de alimentación antes de la instalación o el servicio para evitar descargas eléctricas.
 Atencão: Desconecte da fonte de alimentação antes da instalação ou serviço para evitar choque elétrico
 ВНИМАНИЕ: отключите от источника питания перед установкой или обслуживанием, чтобы предотвратить поражение электрическим током.

AC See D207-06-005

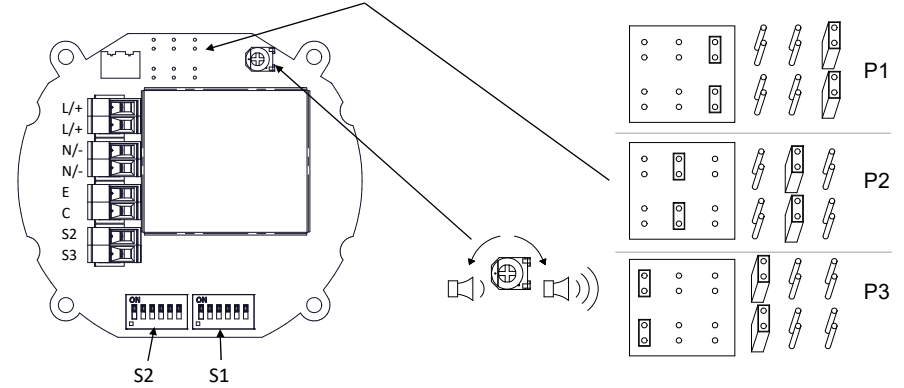

DC See D207-06-001

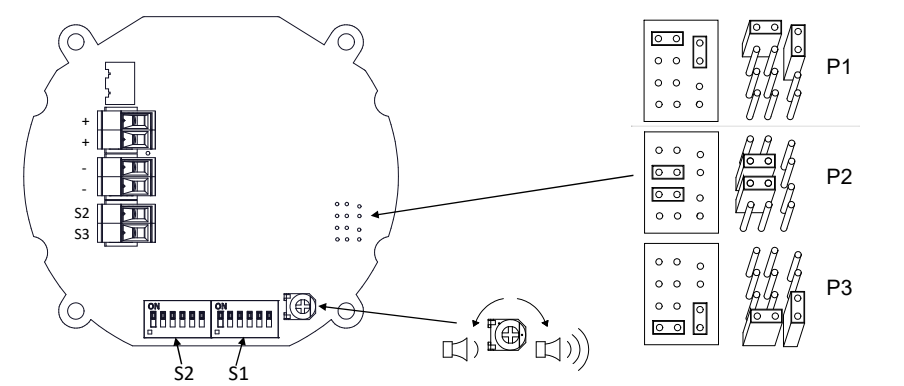

(DC Only, see D207-06-001)

(AC & DC, see D221-95-001)

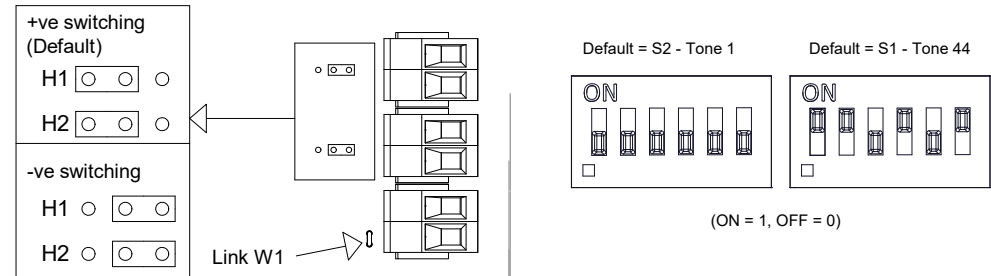

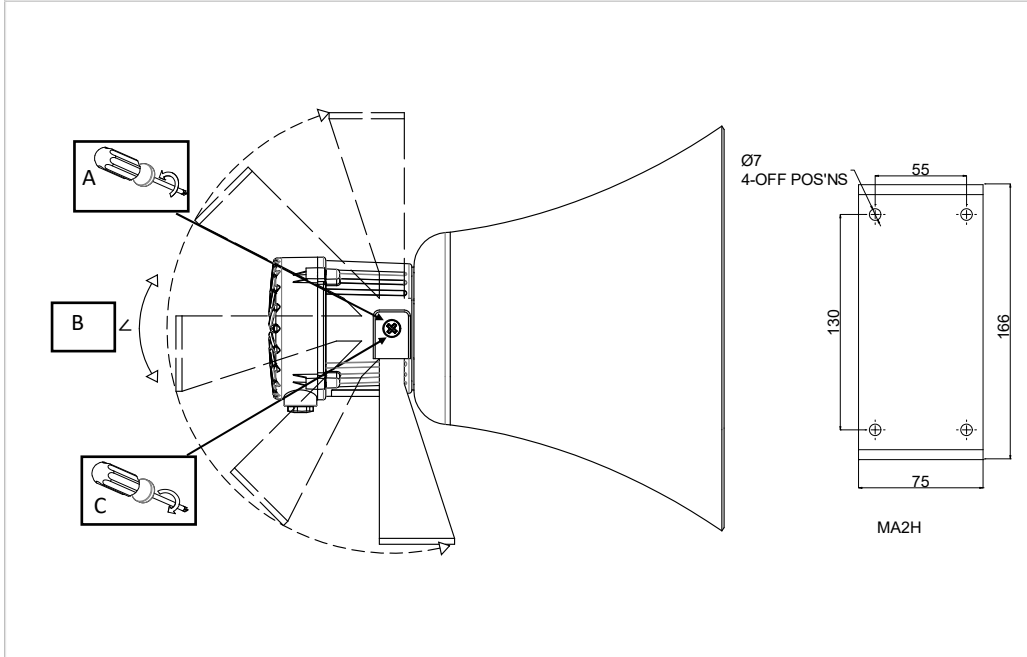
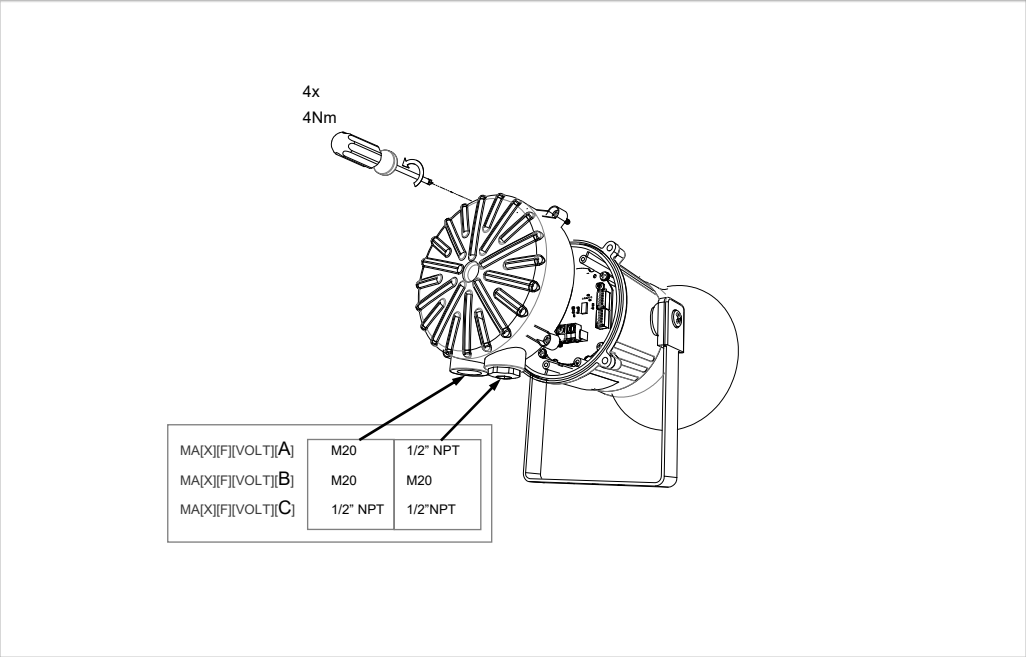
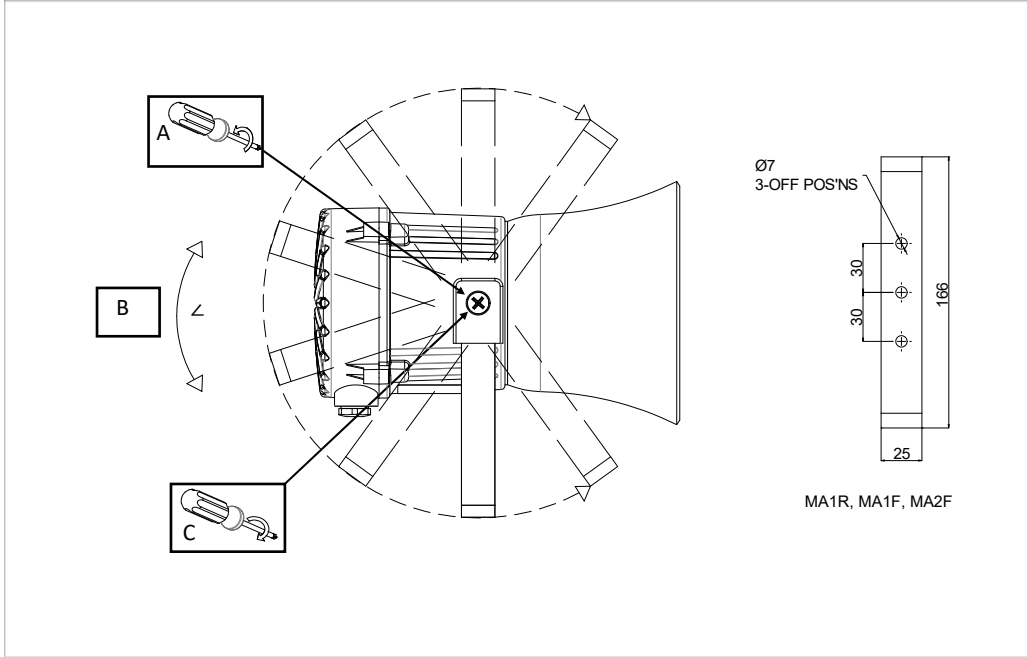

Stage 1 Set DIP SW 1 Tone No.	Tone Description	Tone Visual	Stage 1 & 2 DIP SW 1/2 Settings 1 2 3 4 5 6	Stage 3 Set DIP SW 1 (S3)	Stage 4 Set DIP SW 1 (S2 + S3)
1	1000Hz PFEER Toxic Gas		0 0 0 0 0	2	44
2	1200/500Hz @ 1Hz DIN /PFEER P.T.A.P.		1 0 0 0 0	3	44
3	1000Hz @ 0.5Hz(1s on, 1soff) PFEER Gen. Alarm		0 1 0 0 0 0	2	44
4	1.4KHz-1.6KHz 1s, 1.6KHz-1.4KHz 0.5s NF C 48-265		1 1 0 0 0 0	24	1
5	544Hz(100mS)/440Hz (400mS) NF S 32-001		0 0 1 0 0 0	19	1
6	1500/500Hz - (0.5s on , 0.5s off) x3 + 1s gap AS4428		1 0 1 0 0 0	44	1
7	500-1500Hz Sweeping 2 sec on 1 sec off AS4428		0 1 1 0 0 0	44	1
8	500/1200Hz @ 0.26Hz (3.3son, 0.5s off) Netherlands - NEN 2575		1 1 1 0 0 0	24	35
9	1000Hz (1s on, 1s off)x7 + (7s on, 1s off) IMO Code 1a		0 0 0 1 0 0	34	1
10	1000Hz (1s on, 1s off)x7 + (7s on, 1s off) IMO Code 1a		1 0 0 1 0 0	34	1
11	420Hz(0.5s on, 0.5s off)x3 + 1s gap ISO 8201 Temporal Pattern		0 1 0 1 0 0	1	8
12	1000Hz(0.5s on, 0.5s off)x3 + 1s gap ISO 8201 Temporal Pattern		1 1 0 1 0 0	1	8
13	422/775Hz - (0.85 on, 0.5 off) x3 + 1s gap NFPA - Temporal Coded		0 0 1 1 0 0	1	8
14	1000/2000Hz @ 1Hz Singapore		1 0 1 1 0 0	3	35
15	300Hz Continuous (f=300)		0 1 1 1 0 0	24	35
16	440Hz Continuous (f=440)		1 1 1 1 0 0	24	35
17	470Hz Continuous (f=470)		0 0 0 0 1 0	24	35
18	500Hz Continuous IMO code 2 (Low) (f=500)		1 0 0 0 1 0	24	35
19	554Hz Continuous (f=554)		0 1 0 0 1 0	24	35
20	660Hz Continuous (f=660)		1 1 0 0 1 0	24	35
21	800Hz IMO code 2 (High) (f=800)		0 0 1 0 1 0	24	35
22	1200Hz Continuous (f=1200)		1 0 1 0 1 0	24	35
23	2000Hz Continuous (f=2000)		0 1 1 0 1 0	3	35
24	2400Hz Continuous (f=2400)		1 1 1 0 1 0	20	35
25	440Hz @0.83Hz (50 cycles/minute) Intermittent (f=440, a=0.6, b=0.6)		0 0 0 1 1 0	44	8
26	470Hz @0.9Hz - 1.1s Intermittent (f=470, a=0.55, b=0.55)		1 0 0 1 1 0	44	8
27	470Hz @5Hz - (5 cycles/second) Intermittent (f=470, a=0.1, b=0.1)		0 1 0 1 1 0	44	8
28	544Hz @ 1.14Hz - 0.875s Intermittent (f=470, a=0.43, b=0.44)		1 1 0 1 1 0	24	8
29	655Hz @ 0.875Hz Intermittent (f=655, a=0.57, b=0.57)		0 0 1 1 1 0	44	8
30	660Hz @0.28Hz - 1.8sec on, 1.8sec off Intermittent (f=660, a=1.8, b=1.8)		1 0 1 1 1 0	24	8
31	660Hz @3.34Hz - 150mS on, 150mS off Intermittent (f=660, a=0.15, b=0.15)		0 1 1 1 1 0	24	8
32	745Hz @ 1Hz Intermittent (f=745, a=0.5, b=0.5)		1 1 1 1 1 0	24	8
33	800Hz - 0.25sec on, 1 sec off Intermittent (f=800, a=0.25, b=1)		0 0 0 0 0 1	24	8
34	800Hz @ 2Hz IMO code 3.a (High) Intermittent (f=800, a=0.25, b=0.25)		1 0 0 0 0 1	24	8
35	1000Hz @ 1Hz Intermittent (f=1000, a=0.5, b=0.5)		0 1 0 0 0 1	24	8
36	2400Hz @ 1Hz Intermittent (f=2400, a=0.5, b=0.5)		1 1 0 0 0 1	24	8
37	2900Hz @ 5Hz Intermittent (f=2900, a=0.1, b=0.1)		0 0 1 0 0 1	24	8
38	363/518Hz @ 1Hz Alternating (f=363, f1=518, a=0.1)		1 0 1 0 0 1	8	19
39	450/500Hz @ 2Hz Alternating (f=450, f1=500, a=0.25)		0 1 1 0 0 1	8	19
40	554/440Hz @ 1Hz Alternating (f=440, f1=554, a=0.5)		1 1 1 0 0 1	24	19
41	554/440Hz @ 0.625Hz Alternating (f=440, f1=554, a=0.8)		0 0 0 1 0 1	8	19
42	561/760Hz @0.83Hz (50 cycles/minute) Alternating (f=561, f1=760, a=0.6)		1 0 0 1 0 1	8	19
43	780/600Hz @ 0.96Hz Alternating (f=600, f1=780, a=0.52)		0 1 0 1 0 1	8	19
44	800/1000Hz @ 2Hz Alternating (f=800, f1=1000, a=0.25)		1 1 0 1 0 1	24	19
45	970/800Hz @ 2Hz Alternating (f=800, f1=970, a=0.25)		0 0 1 1 0 1	8	19
46	800/1000Hz @ 0.875Hz Alternating (f=800, f1=1000, a=0.57)		1 0 1 1 0 1	24	19
47	2400/2900Hz @ 2Hz Alternating (f=2400, f1=2900, a=0.25)		0 1 1 1 0 1	24	19
48	500/1200Hz @ 0.3Hz Sweeping (f=500, f1=1200, a=3.34)		1 1 1 1 0 1	24	12
49	560/1055Hz @ 0.18Hz Sweeping (f=560, f1=1055, a=5.47)		0 0 0 0 1 1	24	12
50	560/1055Hz @ 3.3Hz Sweeping (f=560, f1=1055, a=0.3)		1 0 0 0 1 1	24	12
51	600/1250Hz @ 0.125Hz Sweeping (f=600, f1=1250, a=8)		0 1 0 0 1 1	24	12
52	660/1200Hz @ 1Hz Sweeping (f=660, f1=1200, a=1)		1 1 0 0 1 1	24	12
53	800/1000Hz @ 1Hz Sweeping (f=800, f1=1000, a=1)		0 0 1 0 1 1	24	12
54	800/1000Hz @ 7Hz Sweeping (f=800, f1=1000, a=0.14)		1 0 1 0 1 1	24	12
55	800/1000Hz @ 50Hz Sweeping (f=800, f1=1000, a=0.02)		0 1 1 0 1 1	24	12
56	2400/2900Hz @ 7Hz Sweeping (f=2400, f1=2900, a=0.14)		1 1 1 0 1 1	24	12
57	2400/2900Hz @ 1Hz Sweeping (f=2400, f1=2900, a=1)		0 0 0 1 1 1	24	12
58	2400/2900Hz @ 50Hz Sweeping (f=2400, f1=2900, a=0.02)		1 0 0 1 1 1	24	12
59	2500/3000Hz @ 2Hz Sweeping (f=2500, f1=3000, a=0.5)		0 1 0 1 1 1	24	12
60	2500/3000Hz @ 7.7Hz Sweeping (f=2500, f1=3000, a=0.13)		1 1 0 1 1 1	24	12
61	800Hz Motor Siren (f=800, a=1.6)		0 0 1 1 1 1	24	12
62	1200Hz Motor Siren (f=1200, a=2)		1 0 1 1 1 1	24	12
63	2400Hz Motor Siren (f=2400, a=1.7)		0 1 1 1 1 1	24	12
64	Simulated Bell		1 1 1 1 1 1	21	12

1	2	3	4	5	6	7	8	9	10
							ISSUE	MOD No.	REASON - INITIAL - DATE
							B		Configuration titles amended RSR - 19/05/2021
							C	ACN0129	Product Versions Updated RSR - 29/03/2023
							D	ACN0153	OPTIONS Y & V MONITORING DETAILS RSR - 06/06/2024

OPTIONAL LINE MONITORING RESISTOR, CUSTOMER SUPPLIED,
RECOMMENDED MINIMUM VALUES:
14V MAX SYSTEM = 120Ω MIN, 2W MIN OR 1KΩ MIN, 0.5W MIN
28V MAX SYSTEM = 470Ω MIN, 2W MIN OR 2.4KΩ MIN, 0.5W MIN



Single Stage Configuration	Config.: 1a	Two Stage Configuration	Config.: 1b	Three/Four Stage Configuration	Config.: 1c
Line Monitoring Set to positive switching (default)		Common Negative Set to positive switching (default)		Common Negative Set to positive switching (default)	
Stage 1: Apply Power to Stage 1 +ve & Stage 1 -ve		Stage 1: Apply Power to Stage 1 +ve & Common -ve Stage 2: Apply Power to Stage 2 +ve & Common -ve		Stage 1: Apply Power to Stage 1 +ve & Common -ve Stage 2: Apply Power to Stage 2 +ve & Common -ve Stage 3: Apply Power to Stage 3 +ve & Common -ve Stage 4: Apply Power to Stage 2 +ve, Stage 3 +ve & Common -ve	

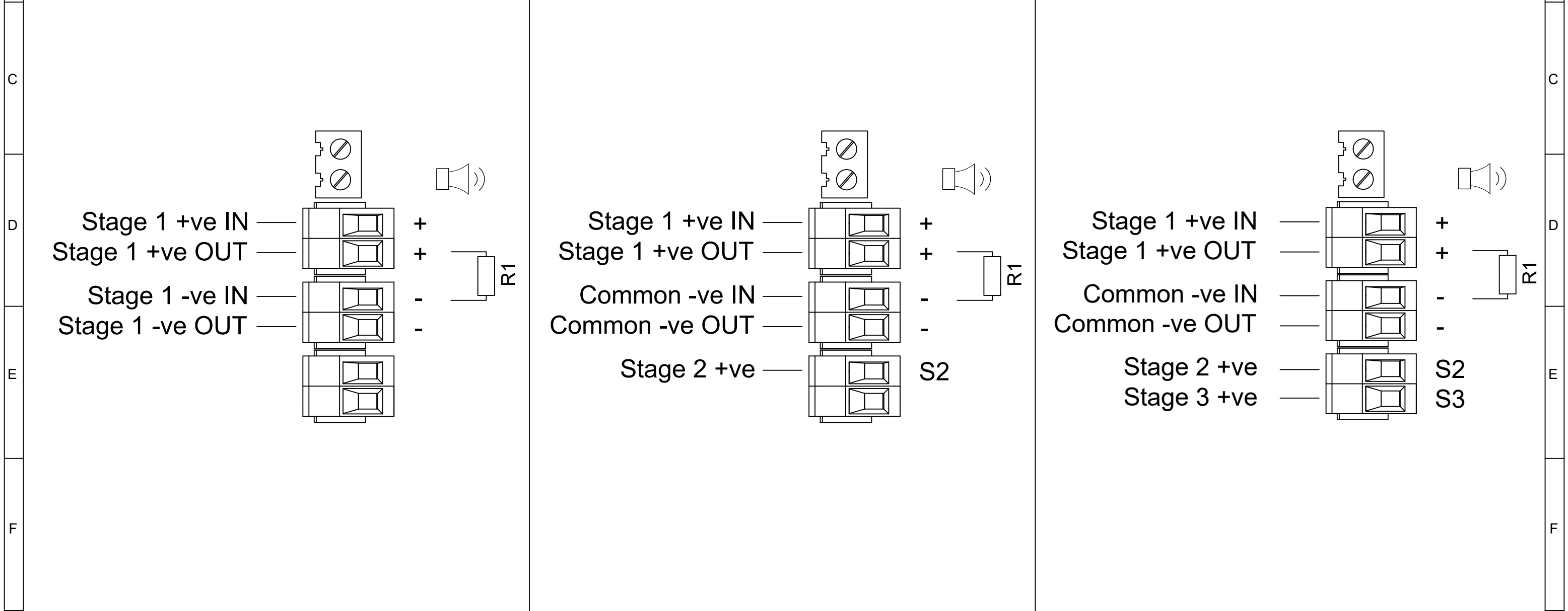

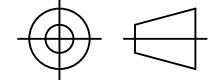
DRAWING TO BS8888:2000 GEOMETRIC TOLERANCES TO ISO1101:1983 LINEAR DIMENSIONAL TOLS ANGULAR DIMENSIONAL TOLS	DRAWN	DATE	SURFACE FINISH	WEIGHT (Kg)	THIS DRAWING AND ANY INFORMATION OR DESCRIPTIVE MATTER THEREIN IS COMMUNICATED IN CONFIDENCE AND IS THE COPYRIGHT PROPERTY OF EUROPEAN SAFETY SYSTEMS LTD. NEITHER THE WHOLE OR ANY EXTRACT MAY BE DISCLOSED, LOANED, COPIED OR USED FOR MANUFACTURING OR TENDERING PURPOSES WITHOUT THEIR WRITTEN CONSENT.	 EUROPEAN SAFETY SYSTEMS LTD IMPRESS HOUSE MANSELL ROAD ACTON LONDON W3 7QH WWW.E2S.COM	ALL DIMENSIONS IN MM		A3
	R.S.RAIT	05/03/2021					MATERIAL		
	CHECKED	DATE	ALTERNATIVE MATERIAL	TITLE MA1R, MA1F, MA2F & MA2H DC SOUNDER WIRING DIAGRAMS					
STANDARDS	B.ISARD	05/03/2021			SCALE	SHEET	DRAWING NUMBER		
M RANGE	R.N.POTTS	05/03/2021			NTS	1 OF 3	D207-06-001		

1	2	3	4	5	6	7	8	9	10
							ISSUE	MOD No.	REASON - INITIAL - DATE
							B		Configuration titles amended RSR - 19/05/2021
							C	ACN0129	Product Versions Updated RSR - 29/03/2023
							D	ACN0153	OPTIONS Y & V MONITORING DETAILS RSR - 06/06/2024

OPTIONAL LINE MONITORING RESISTOR, CUSTOMER SUPPLIED,
RECOMMENDED MINIMUM VALUES:
14V MAX SYSTEM = 120Ω MIN, 2W MIN OR 1KΩ MIN, 0.5W MIN
28V MAX SYSTEM = 470Ω MIN, 2W MIN OR 2.4KΩ MIN, 0.5W MIN



SWITCHES FOR STAGE OPERATION
CUSTOMER SUPPLIED



Three/Four Stages. Voltage Free 2nd, 3rd & 4th Stage Activation Configuration	Config.: 2	Two Stage Configuration	Config.: 3
---	------------	-------------------------	------------

Common Positive Customer Set H1 & H2 to Negative Switching (See Below)	Independent Stage Input Reverse Polarity Stage Monitoring
---	--

Stage 1: Apply Power to Common +ve & Stage 1 -ve Stage 2: Apply Power to Common +ve & Stage 1 -ve & connect Stage 2 -ve to Stage 1 -ve Stage 3: Apply Power to Common +ve & Stage 1 -ve & connect Stage 3 -ve to Stage 1 -ve Stage 4: Apply Power to Common +ve & Stage 1 -ve & connect Stage 2 -ve & Stage 3 -ve to Stage 1 -ve	Stage 1: Apply Power to Stage 1 +ve & Stage 1 -ve Stage 2: Apply Power to Stage 1 +ve & Stage 1 -ve & connect Stage 2 -ve to Stage 1 -ve
--	---

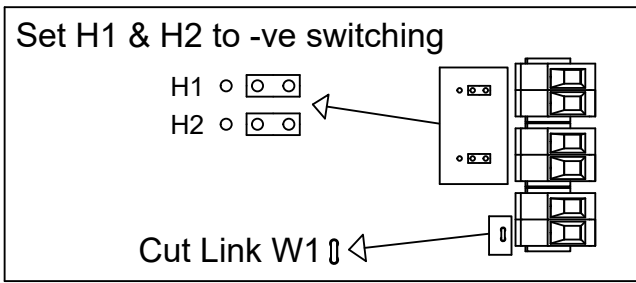
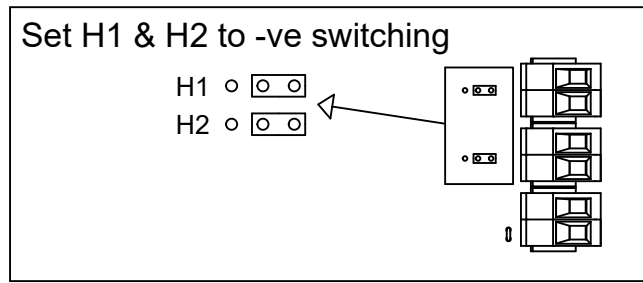
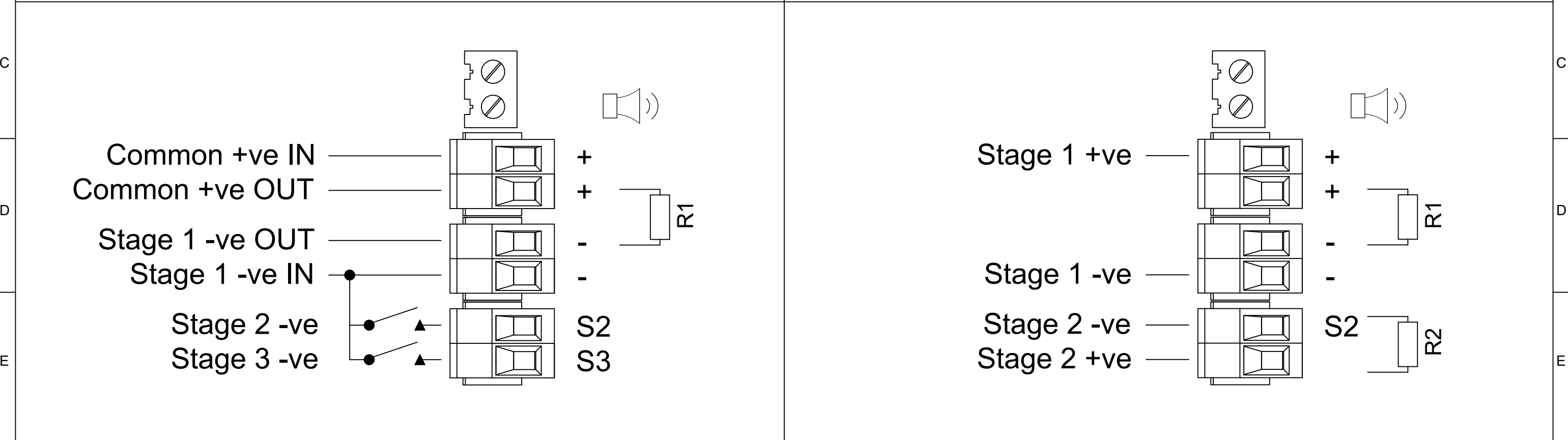

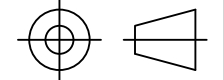
DRAWING TO BS8888:2000 GEOMETRIC TOLERANCES TO ISO1101:1983 LINEAR DIMENSIONAL TOLS ANGULAR DIMENSIONAL TOLS STANDARDS M RANGE	DRAWN R.S.RAIT DATE 05/03/2021	SURFACE FINISH WEIGHT (Kg)	THIS DRAWING AND ANY INFORMATION OR DESCRIPTIVE MATTER THEREIN IS COMMUNICATED IN CONFIDENCE AND IS THE COPYRIGHT PROPERTY OF EUROPEAN SAFETY SYSTEMS LTD. NEITHER THE WHOLE OR ANY EXTRACT MAY BE DISCLOSED, LOANED, COPIED OR USED FOR MANUFACTURING OR TENDERING PURPOSES WITHOUT THEIR WRITTEN CONSENT. © EUROPEAN SAFETY SYSTEMS LTD. AS PER LATEST DATE OF ISSUE SHOWN ABOVE	 EUROPEAN SAFETY SYSTEMS LTD IMPRESS HOUSE MANSELL ROAD ACTON LONDON W3 7QH WWW.E2S.COM	ALL DIMENSIONS IN MM IF IN DOUBT, ASK - DO NOT SCALE		A3
	CHECKED B.ISARD DATE 05/03/2021	MATERIAL			TITLE MA1R, MA1F, MA2F & MA2H DC SOUNDER WIRING DIAGRAMS		
	APPROVED R.N.POTTS DATE 05/03/2021	ALTERNATIVE MATERIAL			SCALE NTS	SHEET 2 OF 3	DRAWING NUMBER D207-06-001
					SCALE NTS	SHEET 2 OF 3	DRAWING NUMBER D207-06-001

1	2	3	4	5	6	7	8	9	10
							ISSUE	MOD No.	REASON - INITIAL - DATE
							B		Configuration titles amended RSR - 19/05/2021
							C	ACN0129	Product Versions Updated RSR - 29/03/2023
							D	ACN0153	OPTIONS Y & V MONITORING DETAILS RSR - 06/06/2024

OPTIONAL LINE MONITORING RESISTOR, CUSTOMER SUPPLIED,
RECOMMENDED MINIMUM VALUES:
14V MAX SYSTEM = 120Ω MIN, 2W MIN OR 1KΩ MIN, 0.5W MIN
28V MAX SYSTEM = 470Ω MIN, 2W MIN OR 2.4KΩ MIN, 0.5W MIN

SWITCHES FOR STAGE OPERATION
CUSTOMER SUPPLIED

Two Stage Configuration	Config.: 4	Two/Three Stage Voltage Free Activation Configuration	Config.: 5	Three/Four Stage Configuration	Config.: 6
Independent power input for alarm stage activation. Line monitoring available for Stage 1 & 2 alarm stage. Line monitoring requires common negative between each power input. Line monitoring maximum voltage: 4Vdc. Not to be used for reverse polarity line monitoring.		Customer Set H1 & H2 to Negative Switching (See Below)		Independent power input for alarm stage activation. Line monitoring available for Stage 1, 2 & 3 alarm stage. Line monitoring requires common negative between each power input. Line monitoring maximum voltage: 4Vdc. Not to be used for reverse polarity line monitoring.	

Stage 1: Apply Power to Stage 1 +ve & Stage 1 -ve Stage 2: Apply Power to Stage 2 +ve & Stage 2 -ve	Power: +ve & -ve Stage 1: Connect Stage 1 -ve to Common -ve Stage 2: Connect Stage 2 -ve to Common -ve Stage 3: Connect both Stage 1 -ve & Stage 2 -ve to Common -ve	Stage 1: Apply Power to Stage 1 +ve & Stage 1 -ve Stage 2: Apply Power to Stage 2 +ve & Stage 2 -ve Stage 3: Apply Power to Stage 3 +ve & Stage 3 -ve Stage 4: Apply Power to Stage 2 +ve & Stage 2 -ve & Apply Power to Stage 3 +ve & Stage 3 -ve
--	---	--

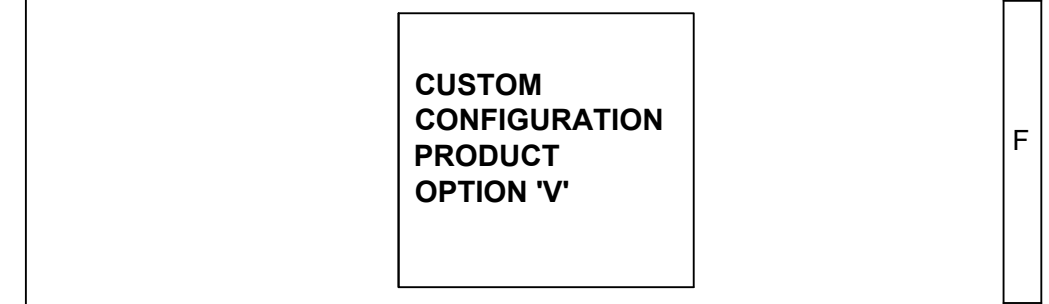
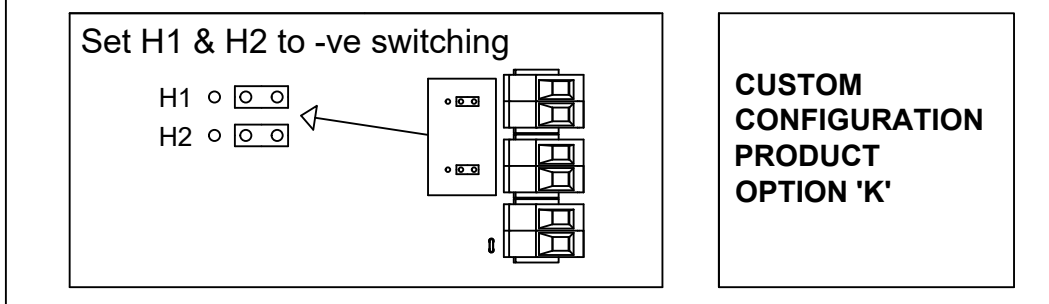
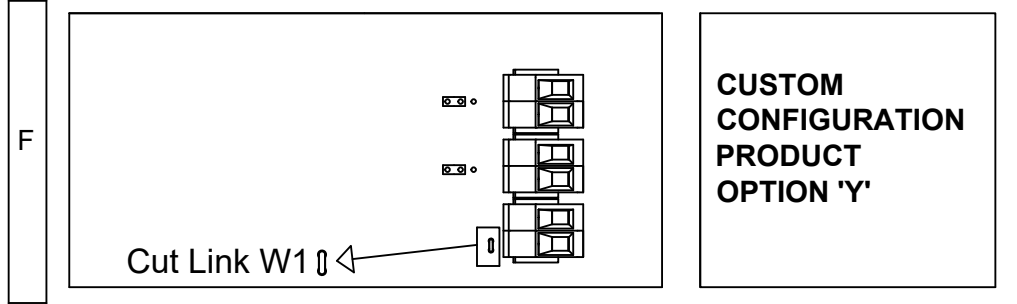
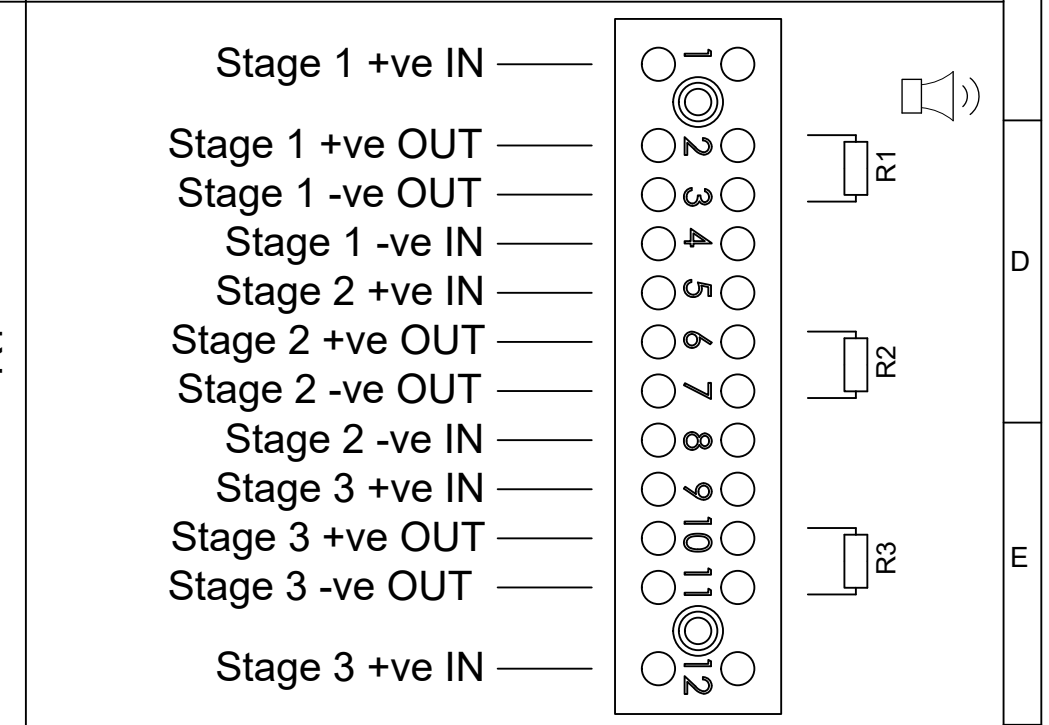
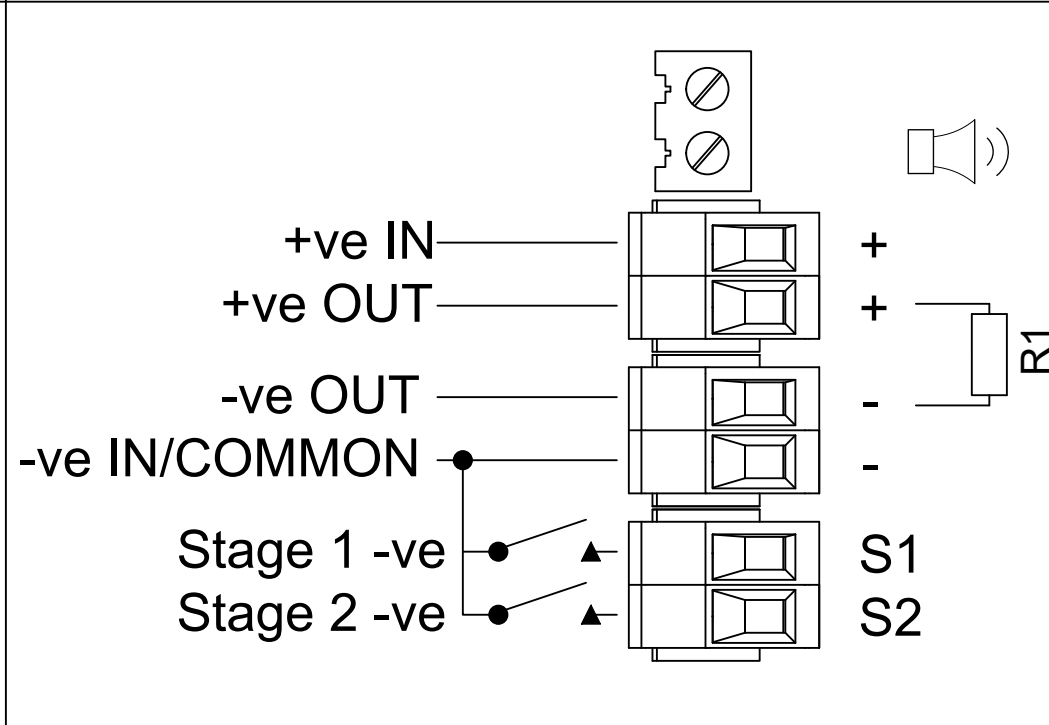
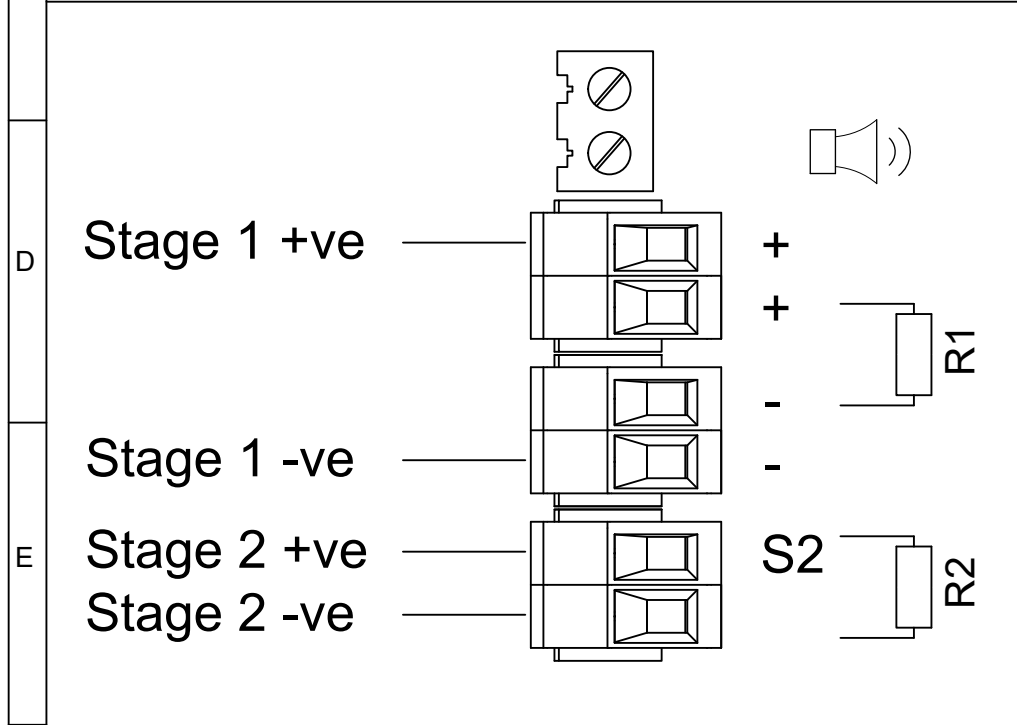

DRAWING TO BS8888:2000 GEOMETRIC TOLERANCES TO ISO1101:1983 LINEAR DIMENSIONAL TOLS ANGULAR DIMENSIONAL TOLS	DRAWN	DATE	SURFACE FINISH	WEIGHT (Kg)	THIS DRAWING AND ANY INFORMATION OR DESCRIPTIVE MATTER THEREIN IS COMMUNICATED IN CONFIDENCE AND IS THE COPYRIGHT PROPERTY OF EUROPEAN SAFETY SYSTEMS LTD. NEITHER THE WHOLE OR ANY EXTRACT MAY BE DISCLOSED, LOANED, COPIED OR USED FOR MANUFACTURING OR TENDERING PURPOSES WITHOUT THEIR WRITTEN CONSENT.	 EUROPEAN SAFETY SYSTEMS LTD IMPRESS HOUSE MANSELL ROAD ACTON LONDON W3 7QH WWW.E2S.COM	ALL DIMENSIONS IN MM			A3
	R.S.RAIT	05/03/2021	MATERIAL				IF IN DOUBT, ASK - DO NOT SCALE			
	CHECKED	DATE	ALTERNATIVE MATERIAL				SCALE	SHEET	DRAWING NUMBER	
STANDARDS	B.ISARD	05/03/2021			NTS	3 OF 3	D207-06-001			
M RANGE	APPROVED	DATE								
	R.N.POTTS	05/03/2021								

ISSUE	MOD No.	REASON - INITIAL - DATE
A		INTRODUCTION RSR - 05/03/2021
B	ACN0129	PRODUCT OPTION K CLARIFIED RSR - 29/03/2023



Single Stage Configuration Config.: 1a Three/Four Stage Configuration Config.: 1b Two Stage Voltage Free Activation Configuration Config.: 2

Stage 1: Apply Power to Stage 1 Live & Stage 1 Neutral
 Stage 1: Apply Power to Live & Neutral
 Stage 2: Apply Power to Live & Neutral & connect Stage 2 to Common
 Stage 3: Apply Power to Live & Neutral & connect Stage 3 to Common
 Stage 4: Apply Power to Live & Neutral & connect both Stage 2 & Stage 3 to Common
 Power: Live & Neutral
 Stage 1: Connect Stage 1 to Common
 Stage 2: Connect Stage 2 to Common
 Stage 3: Connect both Stage 1 & Stage 2 to Common

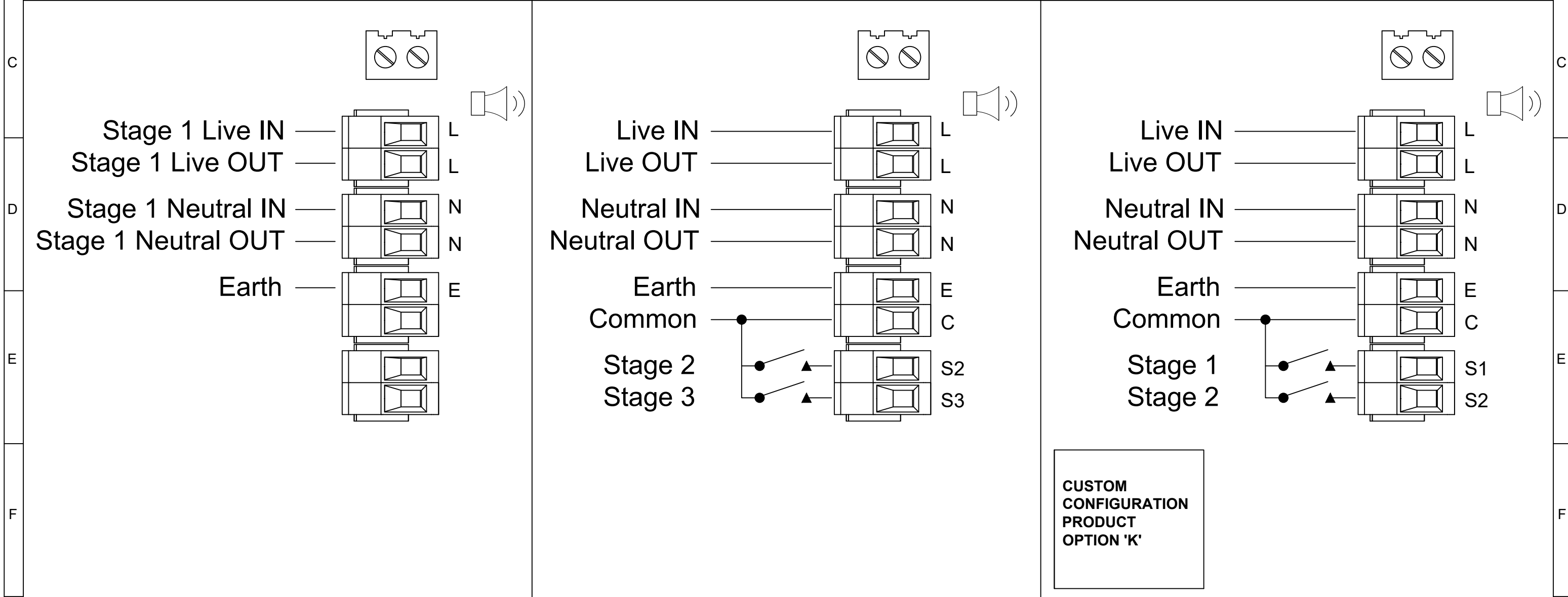

CUSTOM CONFIGURATION PRODUCT OPTION 'K'

DRAWING TO BS8888:2000 GEOMETRIC TOLERANCES TO ISO1101:1983 LINEAR DIMENSIONAL TOLS ANGULAR DIMENSIONAL TOLS	DRAWN R.S.RAIT	DATE 05/03/2021	SURFACE FINISH	WEIGHT (Kg)	THIS DRAWING AND ANY INFORMATION OR DESCRIPTIVE MATTER THEREIN IS COMMUNICATED IN CONFIDENCE AND IS THE COPYRIGHT PROPERTY OF EUROPEAN SAFETY SYSTEMS LTD. NEITHER THE WHOLE OR ANY EXTRACT MAY BE DISCLOSED, LOANED, COPIED OR USED FOR MANUFACTURING OR TENDERING PURPOSES WITHOUT THEIR WRITTEN CONSENT.	EUROPEAN SAFETY SYSTEMS LTD IMPRESS HOUSE MANSSELL ROAD ACTON LONDON W3 7QH WWW.E2S.COM	ALL DIMENSIONS IN MM IF IN DOUBT, ASK - DO NOT SCALE			A3
	STANDARDS M RANGE	CHECKED B.ISARD	DATE 05/03/2021	MATERIAL			TITLE MA1R, MA1F, MA2F, MA2H AC SOUNDER WIRING DIAGRAMS			
		APPROVED R.N.POTTS	DATE 05/03/2021	ALTERNATIVE MATERIAL			SCALE NTS	SHEET 1 OF 1	DRAWING NUMBER D207-06-005	